



Book 1

Flute



by Andrew Scott

illustrated by
Matt Bridges

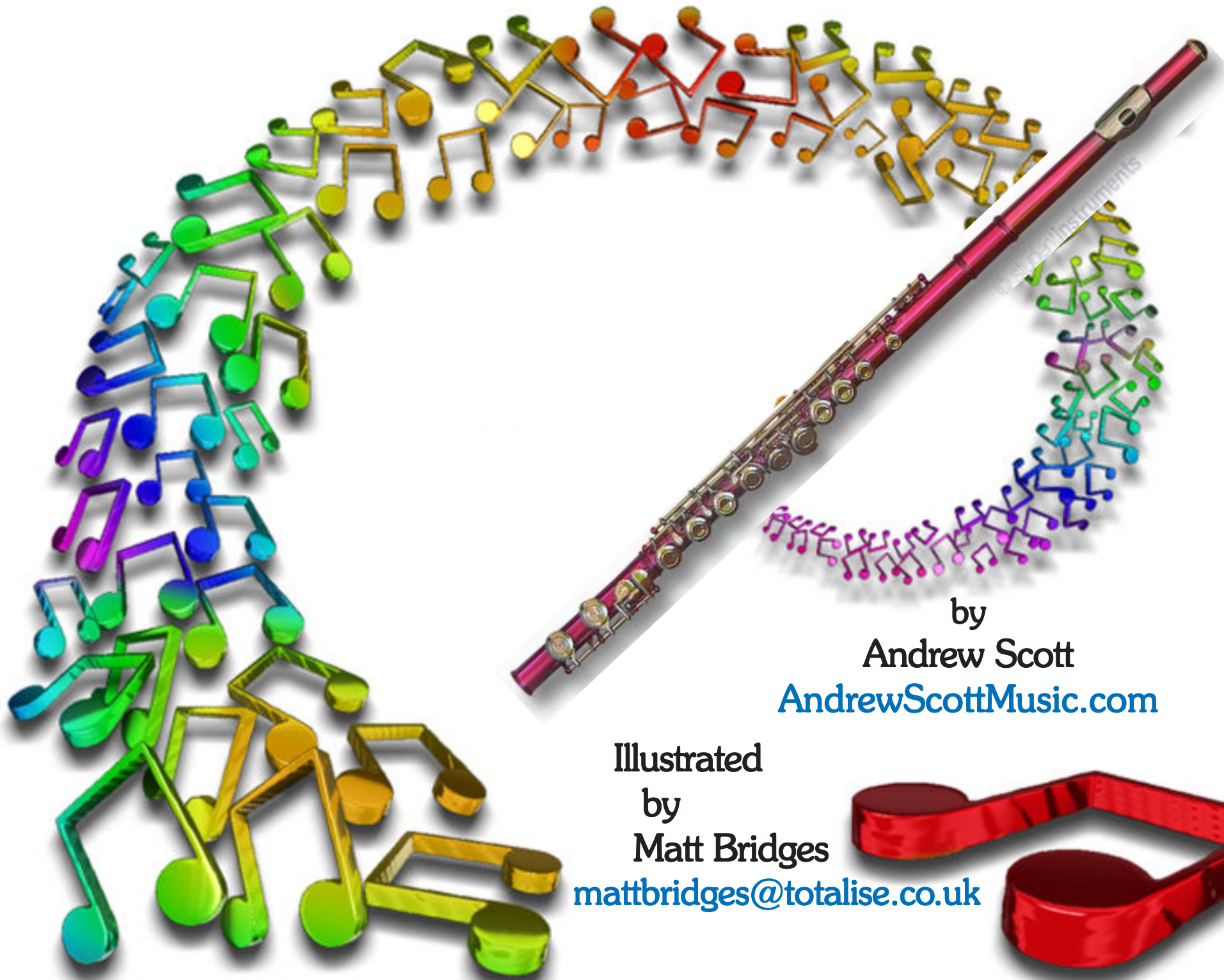

by
Andrew Scott
AndrewScottMusic.com

Illustrated
by
Matt Bridges
mattbridges@totalise.co.uk

Contents

Lesson 1

The Note B 3
 The Staff
 Notes
 The Clef
 The Time Signature
 Rests
 Ben the Bee 4
 Be Good Ben
 Toot a Toot
 Hear Ben the Bee 5
 Repeat Dots
 Fly About Ben
 Left Right Left

Lesson 2

The Note A 6
 Ann the Ant
 Ask an Ant
 Creepy Crawl 7
 Tip of My Tongue
 Tots in Tu-Tus

Lesson 3

The Note G 8
 George the Giraffe
 Fingers for G
 Dark Blue Tongue 9
 G for Me
 Cover Four Holes

Lesson 4

The Half Note (or Minim) 10
 The Half Rest (or Minim Rest)
 Two Rest Two
 Fly Me for Two
 Two Beat B 11
 Cha Cha Cha

Lesson 5

Ben and Ann 12
 Ann and George
 Two Note Rock 13
 Ben and Ann Swing
 Walk and Talk

Lesson 6

Yankee Doodle 14
 Hot Cross Buns
 In the Light of the Moon 15
 Merrily

Lesson 7

The Note C 16
 Coco the Cat
 Coco Sat on a Mat
 C Two Rest Two 17
 See Me

Lesson 8

C and A Exercise 18
 ABC Song
 Shave and a Haircut 19
 Four Note Song

Lesson 9

The Note D 20
 Dan the Dog
 Run, Dan, Run
 Dan Likes a Pat 21
 Dancing up the Stairs

Lesson 10

Finger Fun 22
 Mary Had a Little Lamb
 Five Note Frolic 23
 Ode to Joy

Lesson 11

Aura Lee 24
 Lightly Row
 Changing from D to G 25
 Spare Change

Lesson 12

Jingle Bells 26
 When the Saints Go Marchin' In 27
 Quiz 28

Fingerings Inside Back Cover



Lesson 1

Parts of the Flute

A flute is made up of three pieces – the headjoint, the middle joint and the footjoint.

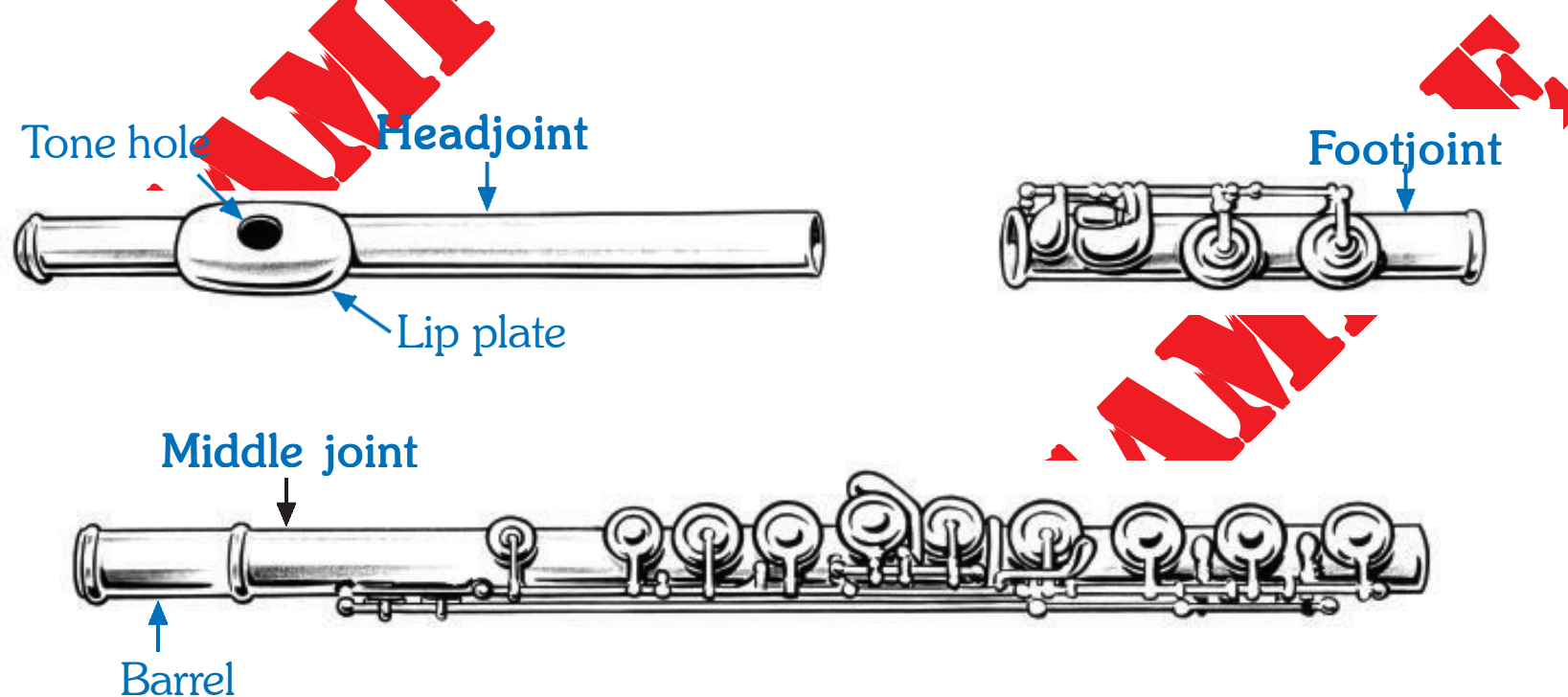

Making a Sound on the Headjoint

Hold the headjoint with both hands as shown in the picture below.

Cover about a quarter of the tone hole with your lower lip.

Blow gently across the hole towards the opposite edge. The headjoint should make a sound.

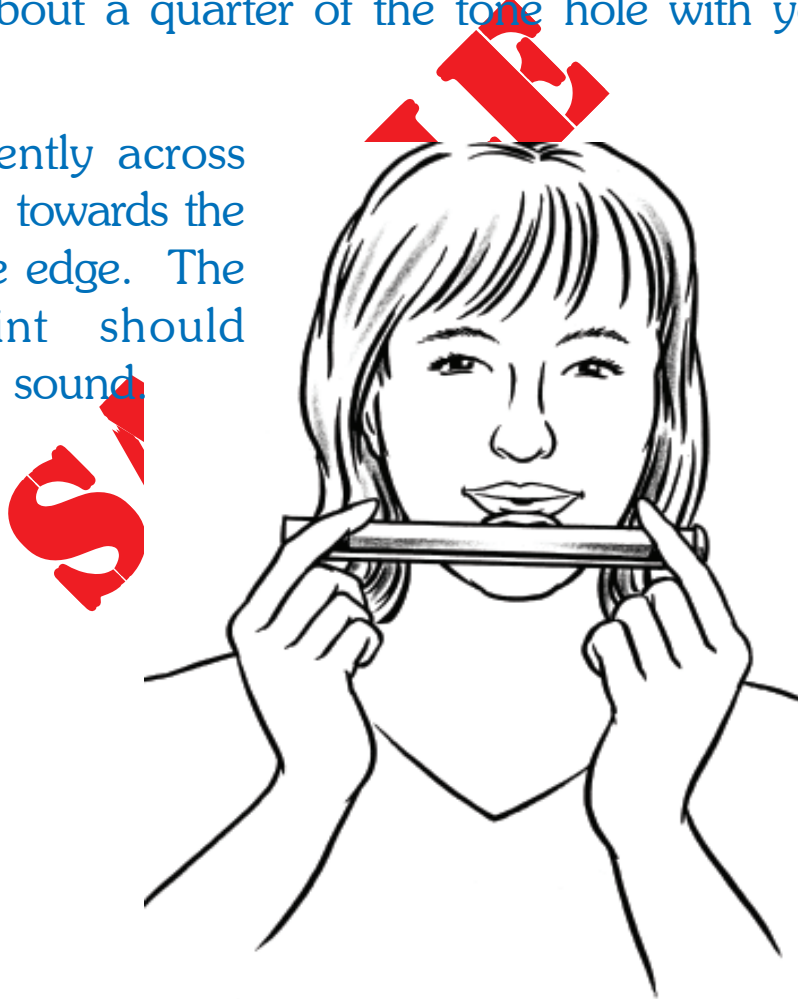

If you can't make a sound, try moving the headjoint a little to the left or the right, or rolling it in towards you or out away from you.

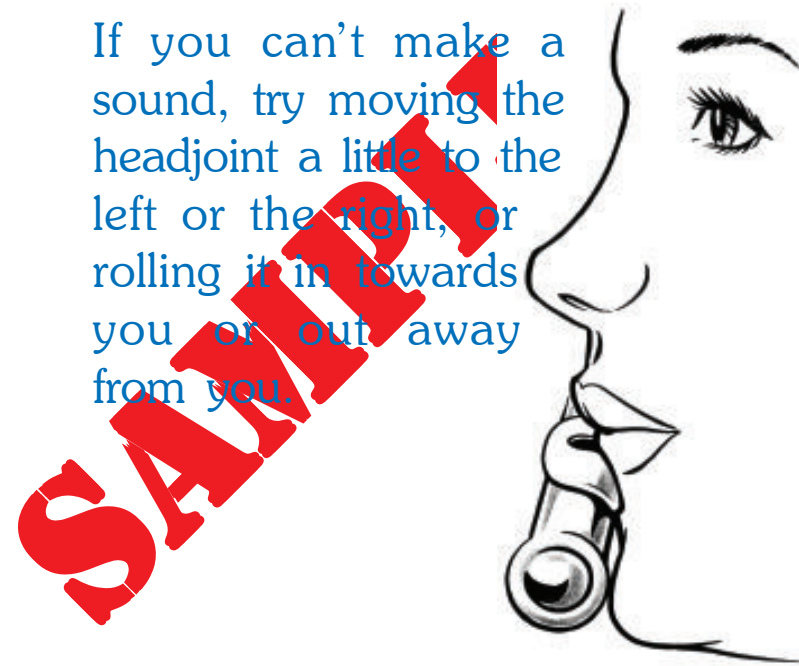

Sometimes it helps to look in a mirror while you are learning to make the sound.

When you can make a sound, go on to the next page.

Putting the Flute Together

When you pick up the middle joint, make sure you hold it by the barrel. Try not to grip the keys because too much pressure can bend them. As you insert the headjoint into the middle joint, twist it back and forth to help it slip in more smoothly.

Line up the mouth hole with the key on the middle joint.

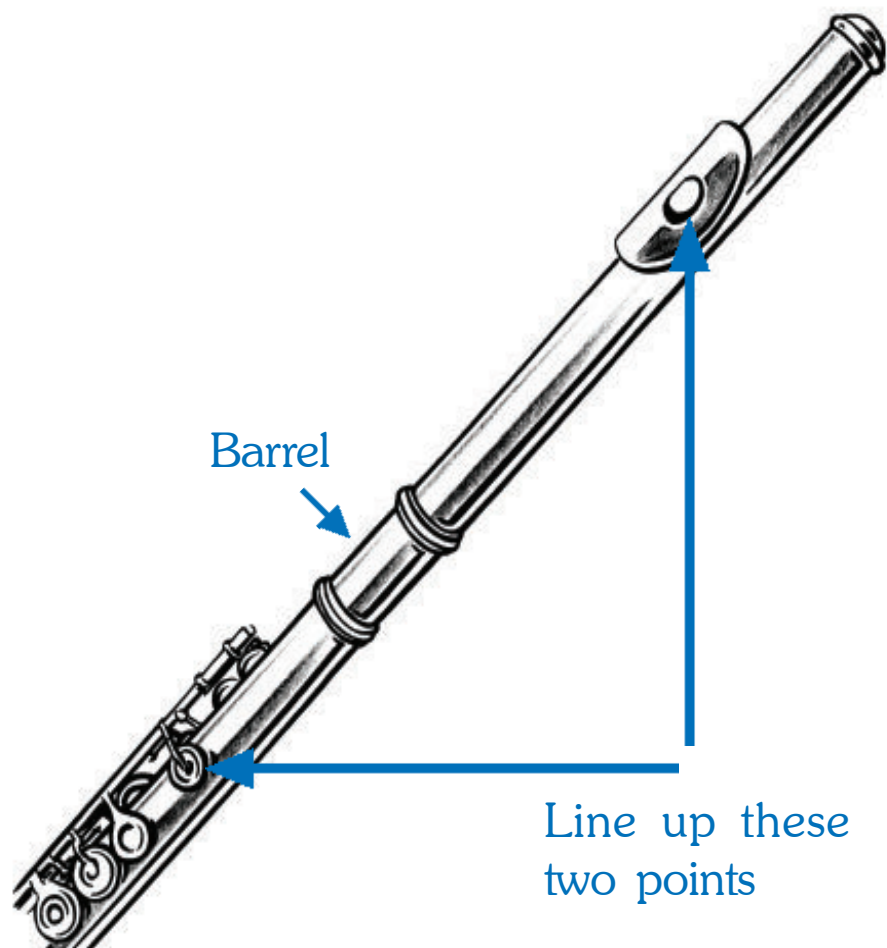

Attach the foot joint to the middle joint, then line them up as shown.

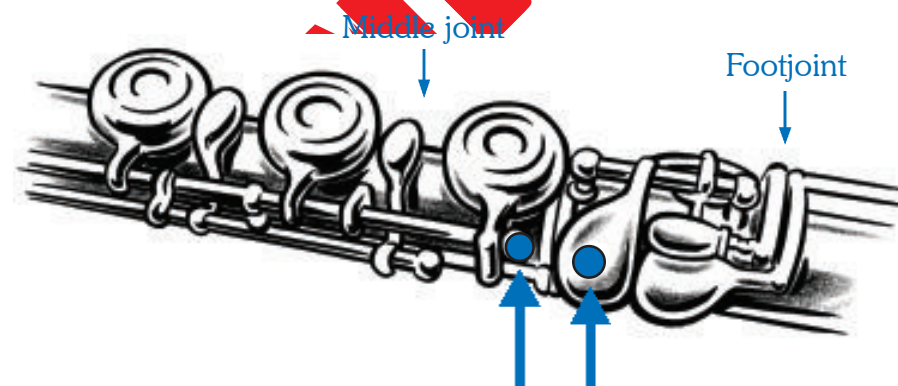

Playing Position

Make sure the flute extends to your right, not your left. Turn your left hand so that its palm faces toward you, and your right hand so that its palm faces away.



Finger Numbers



Left Hand

Right Hand

Each finger gets a number. The left thumb gets a letter - T. The right thumb doesn't play any notes, so it doesn't get a number or a letter.

Are you ready to learn your first note?

Lesson 2

The Note B

Start each note with your tongue, as if you are saying the word "too."

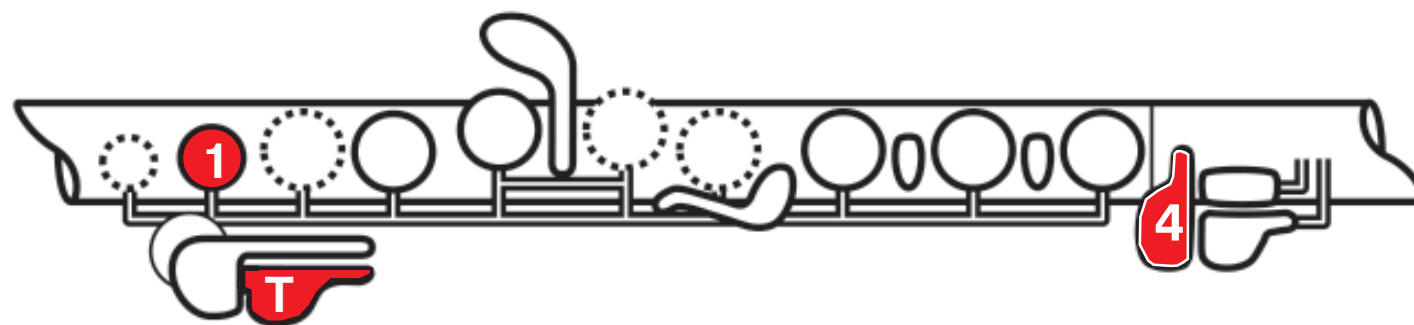

We play notes to make music.

Staff (or Stave)

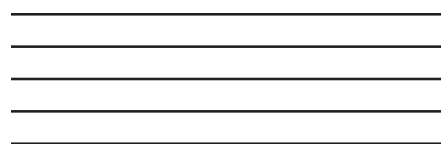

We write notes on the staff..



Clef

The clef tells us where to write notes on the staff.



Note

This is a Quarter Note (or Crotchet) We play it for one beat.



Time Signature

The time signature tells us how to count notes.



Rest

This rest means that we don't play any note, just count one beat.

4

1. Say the Words.

2. Clap the Words.

3. Play the Notes

Ben the Bee



Track 1



Start playing after you hear 4 beats on the tamborine.

Play each song twice.

Musical notation for 'Ben the Bee' in 4/4 time. The melody consists of quarter notes on the G line (B4) and quarter rests. The lyrics are: Ben the bee. Ben the bee. Ben, Ben, Ben the bee.

Be Good Ben!



2

Quarter Note
(or Crotchet)
1 beat

Tongue each note.

Musical notation for 'Be Good Ben!' in 4/4 time. The melody consists of quarter notes on the G line (B4) and quarter rests. The lyrics are: Be good Ben Be a good bee! Be good Ben Be a good bee!



Stylized musical notation for 'Toot a Toot!' featuring a large yellow treble clef and wavy lines representing the melody. The lyrics are: TOOT A TOOT! TOOT A TOOT!

Toot a Toot



3

Musical notation for 'Toot a Toot' in 4/4 time. The melody consists of quarter notes on the G line (B4) and quarter rests. The lyrics are: Toot a toot, toot. Toot a toot, toot. Toot, toot. Toot a toot, toot.



Hear Ben the Bee



Tongue each note.



Buzz!

Buzz!



Hear Ben the Bee tongue ev-ery note. Starts with his tongue and not with his throat!

Fly About Ben



Repeat Dots
These two dots tell us to repeat once from the start.

Ben Bee, fly a-bout fast. Buzz Ben, as you fly past.



Left Right Left



Where are your hands?

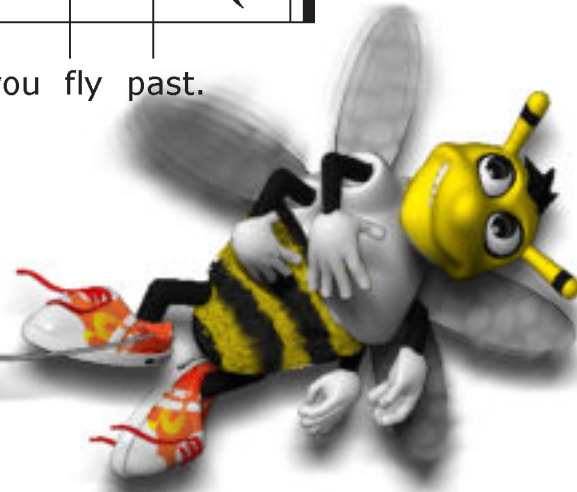

Left hand up, right hand down. Left at the top, not the oth-er way - a - round.

Lesson 3

The Note A

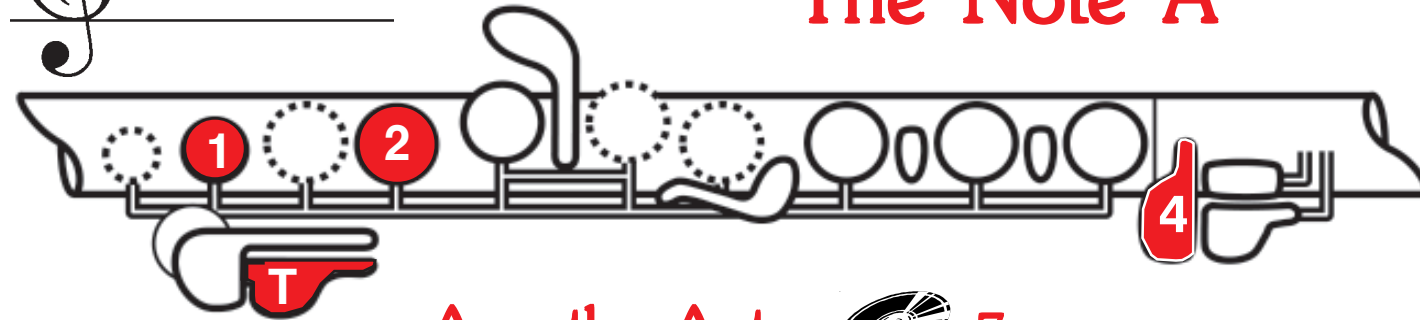
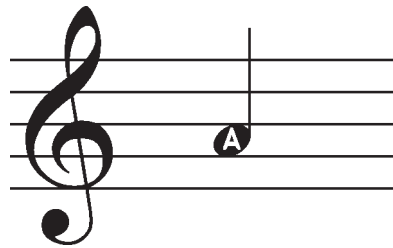

Ann the Ant  7

Remember to keep your thumb in the right spot.



Ann the ant. Ann the ant.



Ann, Ann, Ann the ant.

Ask an Ant



Clap, then play.



Ask an ant, ask an - y ant. Ask an ant, ask an - y ant.



Creepy Crawl  9

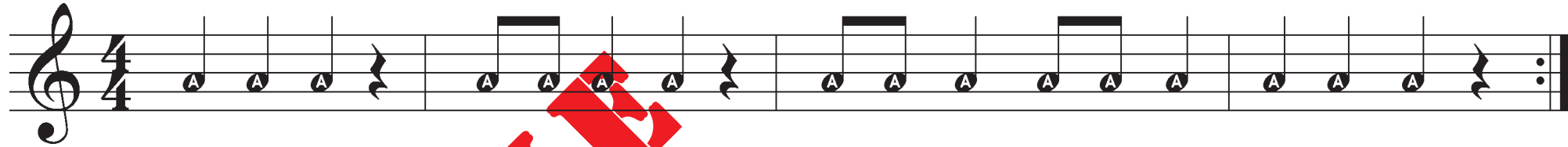

Ann the Ant, What a cute ant! cree-py crawl, cree-py crawl up the plant.

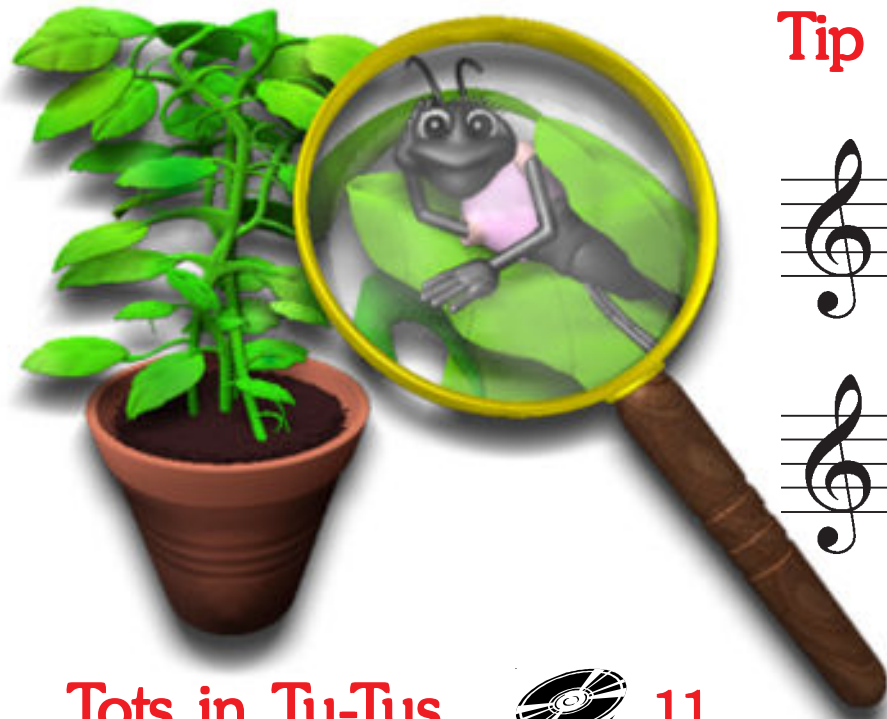

Tip of My Tongue  10



Tip of my tongue, tip of my tongue.

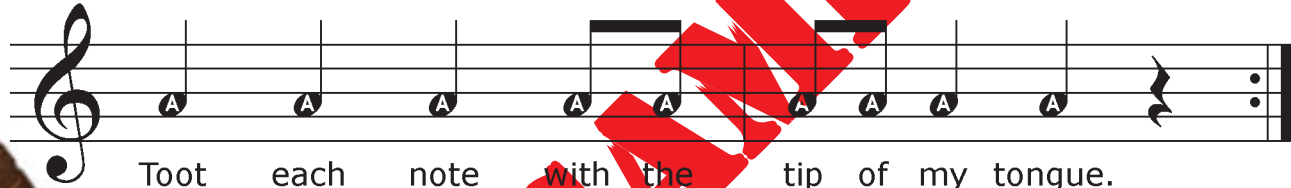

Toot each note with the tip of my tongue.

Tots in Tu-Tus  11

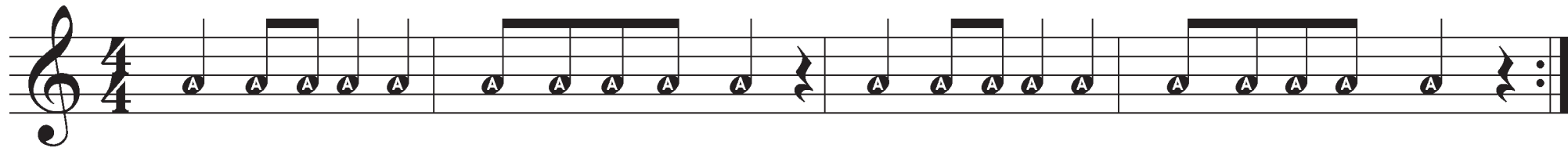

Two tots in tu-tus danc-ing un-der trees. Two tots in tu-tus danc-ing in the breeze.

SAMPLE

Lesson 4

The Note G



A musical staff showing a single G note on the first line. Below it is a diagram of a hand with fingers numbered 1-4 and a 'T' for thumb, indicating the fingerings for the note G.

George the Giraffe



George the Giraffe, George the Giraffe stands ve - ry tall and he

1/2 a beat each

A musical staff in 4/4 time with lyrics. A red watermark 'SALE' is overlaid. A blue arrow points to the eighth notes in the phrase 'stands ve - ry tall' with the text '1/2 a beat each'.

likes a good laugh.

A musical staff in 4/4 time with lyrics.

Fingers for G



Thumb and one, two three, fin - gers for G. Fin - gers for G, thumb and one, two, three.

A musical staff in 4/4 time with lyrics.

Dark Blue Tongue 14

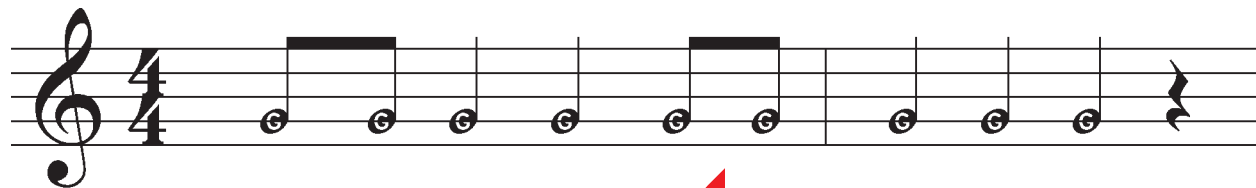

George the gir - affe with his head up high,



dark blue tongue as he licks at the sky.

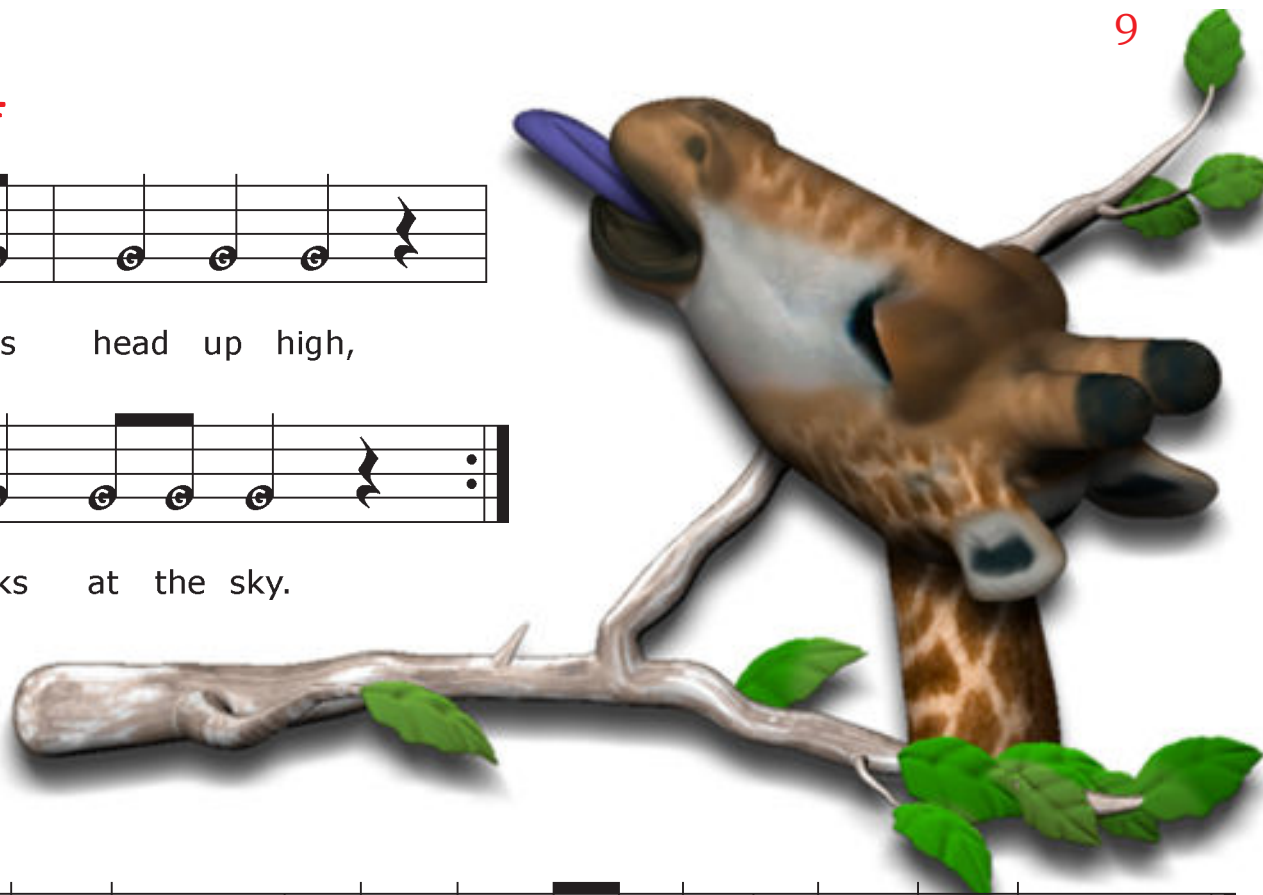

G for Me 15

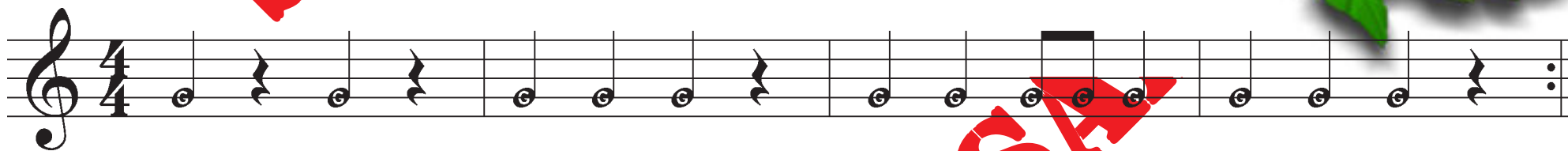

G, G, G for me! It's as ea - sy as 1 2 3!

Cover Four Holes 16

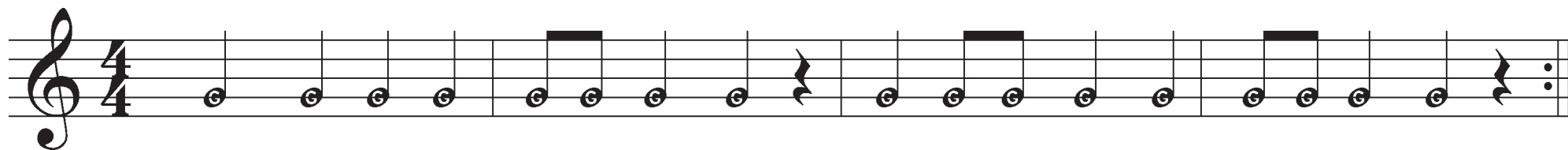

Stretch those fin - gers, co - ver four holes. No gaps al - lowed, it's one of our goals.



10

Ann Ran Track

1 Ann ran up a can ly - ing on the sink.

2

3 Ben knew, as he flew, 4 Ann wan - ted a drink.

George Talked Track

1 George talked as he walked 2 slow - ly on the sand.

3 Ann heard ev - ery word, 4 she thought he was grand.

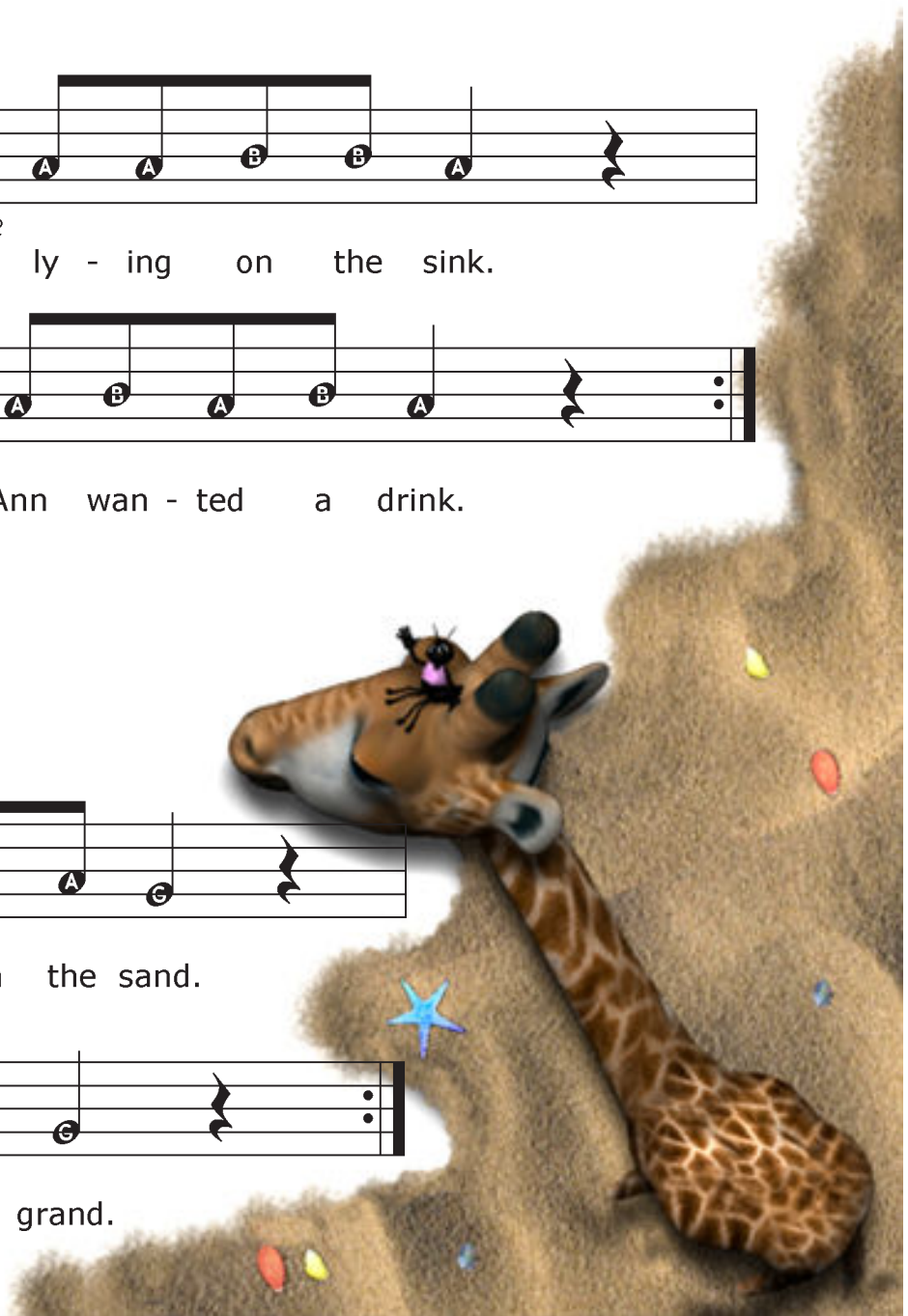

Lesson 5

The Half Note (or Minim)



Hold these notes for two beats each.



The Half Rest (or Minim Rest)

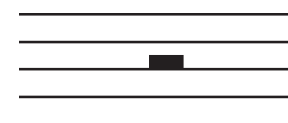

Count two beats for this rest.

B Two Rest Two 17

B two rest two. B two rest two. B two three four B two rest two.

Play Me for Two 18

Are you still tonguing each note?

Play me for two. Two beats, yes two.



Two Beat B 19



The space between two lines is called a bar.

Two beat B. Two beat B. Two beats on B, two beats on B, two beat B.

Two beats on B, two beats on B, two beat B.

Detailed description: This block contains two staves of musical notation in 4/4 time. The first staff shows a sequence of notes: a half note B, a half note B, a quarter note B, a quarter rest, a half note B, a half note B, a quarter note B, and a quarter rest. A yellow bar highlights the second and third measures. The second staff shows a sequence of notes: a half note B, a quarter note B, a quarter note B, a quarter note B, a half note B, a half note B, a quarter note B, a quarter note B, a half note B, a half note B, a quarter note B, and a quarter rest. A red triangle points to the eighth measure.



Time Signature
means there are 4 beats in each bar.



Cha Cha Cha 20



Rest, two cha cha cha_, rest, two cha cha cha_,
rest, two cha cha cha_, cha_____.

Detailed description: This block contains two staves of musical notation in 4/4 time. The first staff shows a sequence of notes: a half rest, a quarter note A, a quarter note A, a quarter note A, a half rest, a quarter note A, a quarter note A, a quarter note A. The second staff shows a sequence of notes: a half rest, a quarter note A, a quarter note A, a quarter note A, a half note A, a half rest.

Lesson 6



13
Quarter Note
(or Crotchet)



Ben and Ann



21

Ben flies fast, Ann crawls past.

Ben, Ann, Ben, Ann, who comes last?

SAMPLE



Half Note
(or Minim)

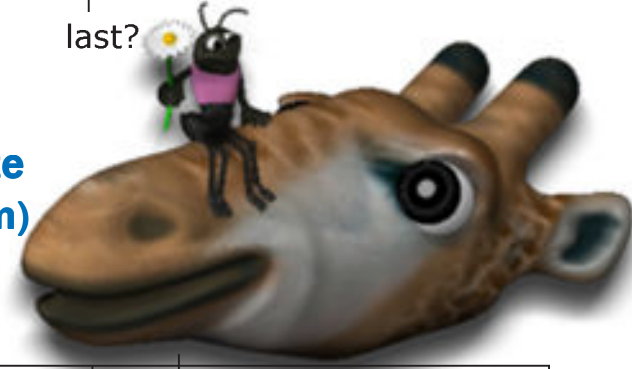

Ann and George



22

Ann crawls past, George runs fast.

Ann, George Ann, George who goes last?

SAMPLE

18

Two Note Rock 23



Rock - ing a - round,
Fin - ger up and down.



Quarter
(or Crotchet)
Rest

Ben and Ann Swing 24

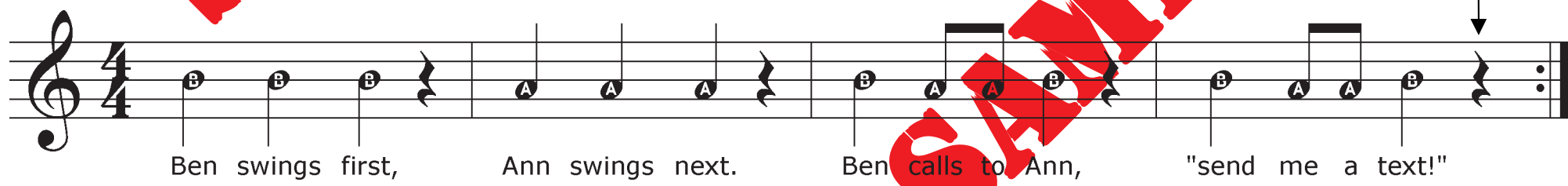

Ben swings first, Ann swings next. Ben calls to Ann, "send me a text!"

Walk and Talk 25



Ann likes to talk, George likes to walk. walk and talk, talk and walk.

Lesson 7



Yankee Doodle 26

Musical notation for "Yankee Doodle" in 4/4 time. The melody consists of two lines of music. The first line contains the notes G4, G4, A4, B4, G4, B4, A4, and a quarter rest. The second line contains G4, G4, A4, B4, G4, G4, and a quarter rest. The lyrics are: "Yan - kee Doo - dle went to town, ri - ding on a po - ny."

Hot Cross Buns 27



Musical notation for "Hot Cross Buns" in 4/4 time. The melody consists of one line of music. The notes are B4, A4, G4, B4, A4, G4, B4, B4, B4, B4, A4, A4, A4, A4, B4, A4, G4. The lyrics are: "Hot Cross Buns! Hot Cross Buns! One a pen - ny, two a pen - ny, Hot Cross Buns!"

20

In the Light of the Moon



28

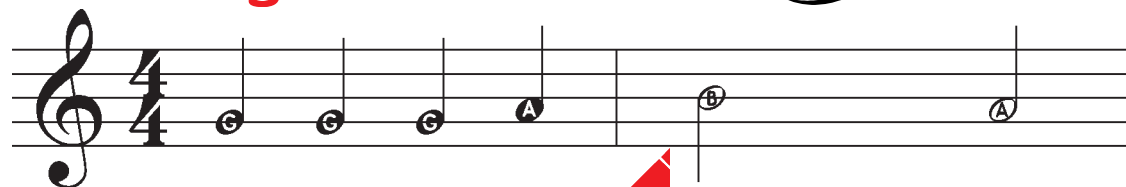

I will meet you so _____ -on,

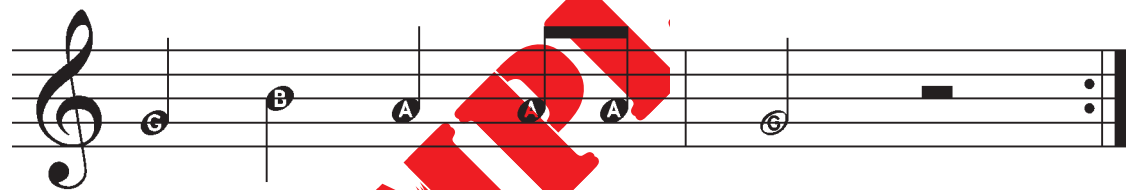

in the light of the moon.

SAMPLE

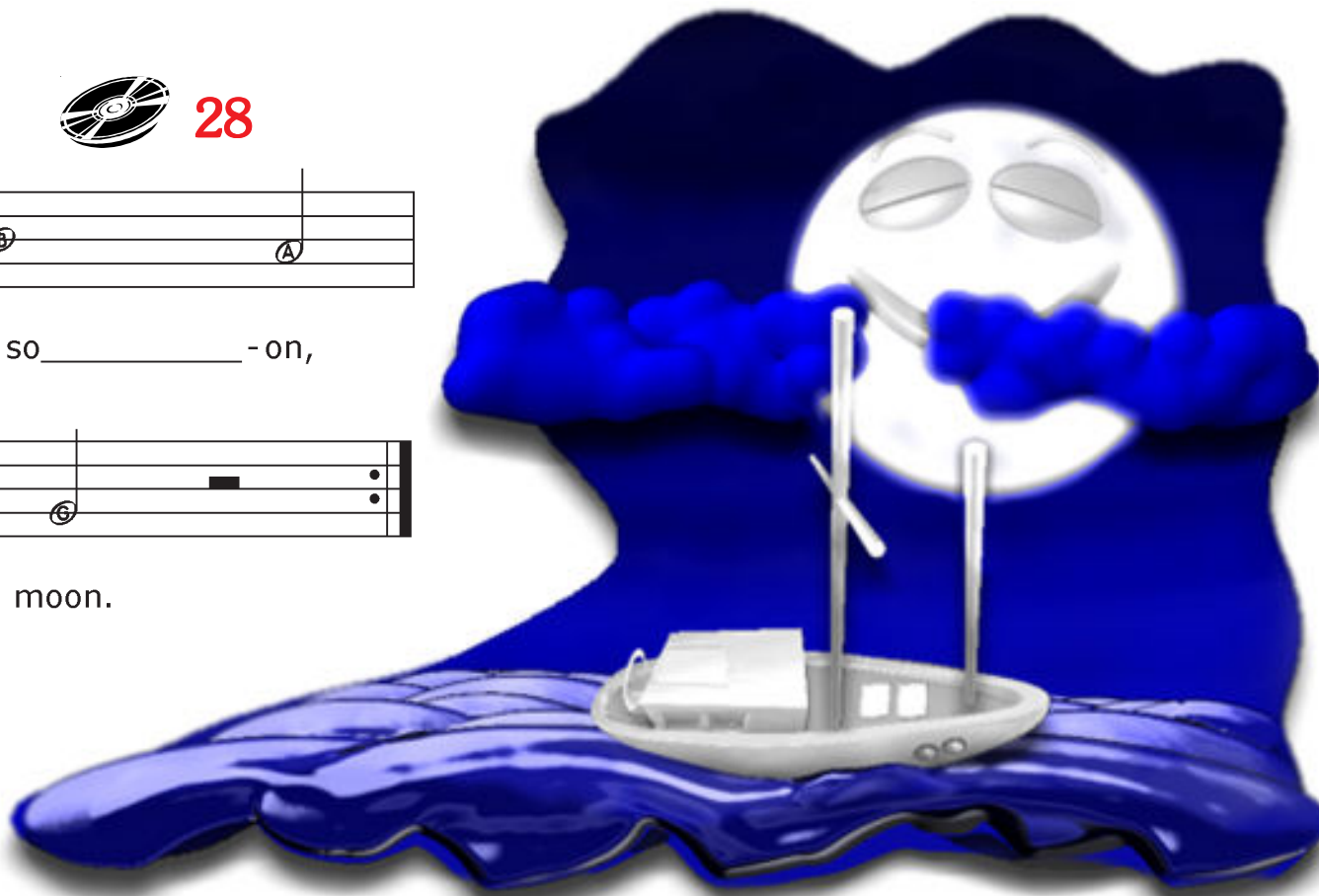

Merrily



29

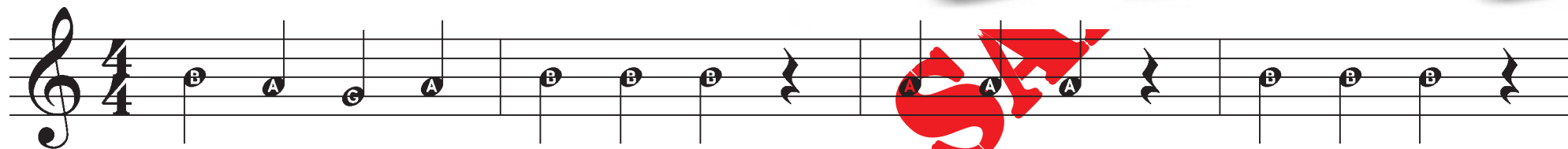

Mer - ri - ly we roll a - long, roll a - long, roll a - long,

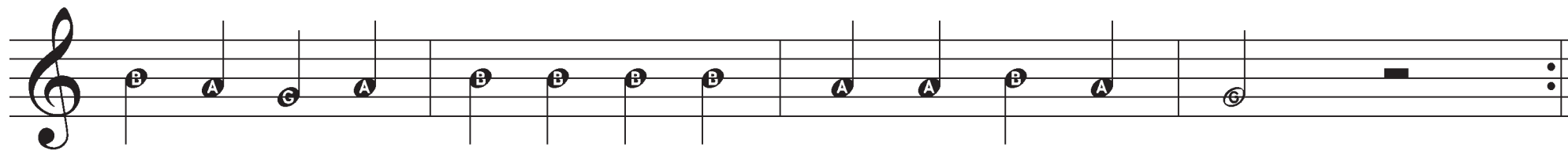

mer - ri - ly we roll a - long a - cross the deep blue sea.

Lesson 8



The Note C

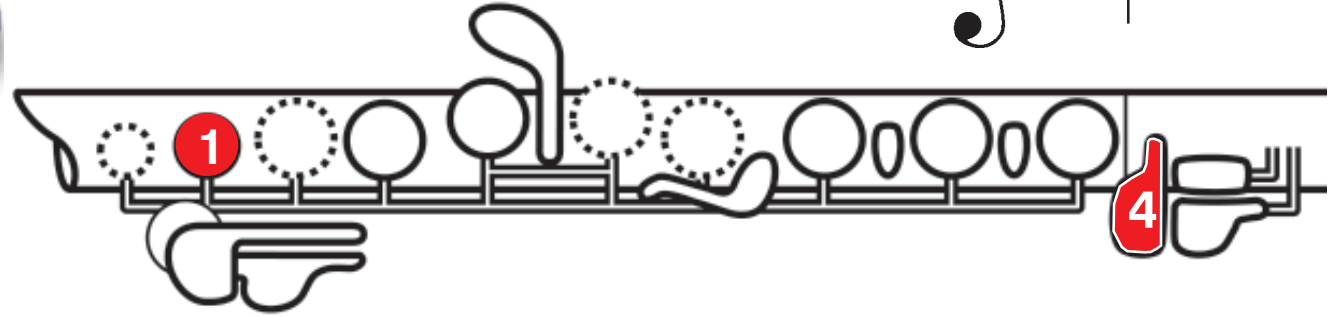

Coco the Cat 30

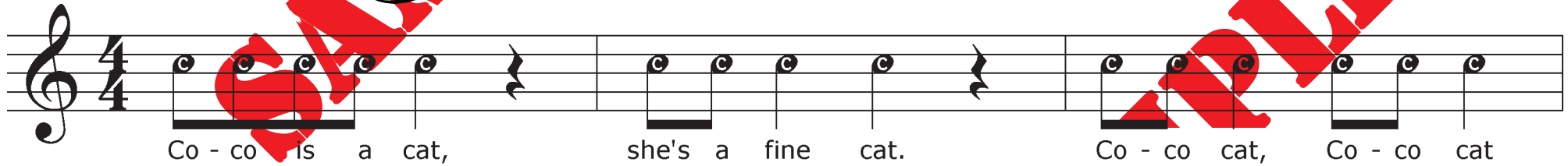

Co - co is a cat, she's a fine cat. Co - co cat, Co - co cat

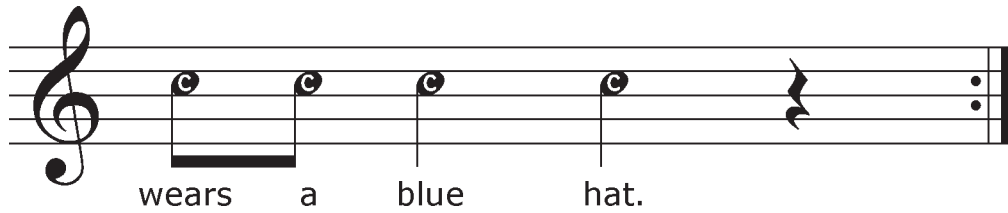

wears a blue hat.

Coco Sat on a Mat 31

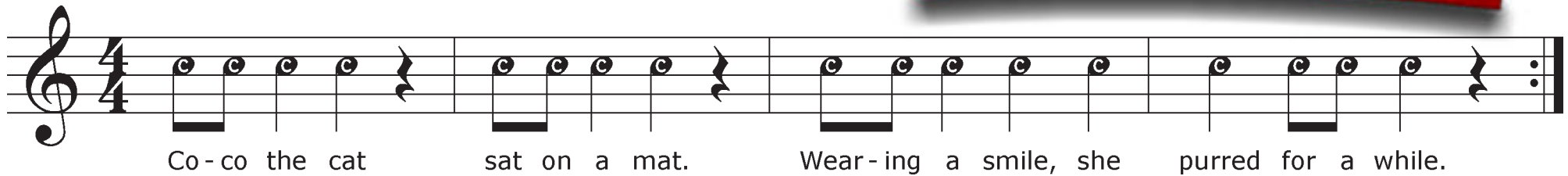

Co-co the cat sat on a mat. Wear-ing a smile, she purred for a while.



22

C Two Rest Two 32

C two rest two. C two rest two. C two three four C two rest two.



See Me 33

See, see me! See, see me!

I'm in a tree, I'm in a tree, See, see me.

Lesson 9

C and A Exercise



34

Two staves of musical notation in 4/4 time. The first staff contains a sequence of notes: C4 (quarter), A3 (quarter), C4 (quarter), A3 (quarter), C4 (quarter), A3 (quarter), and a whole rest. The second staff contains a sequence of notes: A3 (quarter), C4 (quarter), A3 (quarter), C4 (quarter), A3 (quarter), C4 (quarter), and a whole rest.

SAMPLE



ABC Song



35

Two staves of musical notation in 4/4 time. The first staff contains notes for the lyrics: C4 (quarter), A3 (quarter), C4 (quarter), A3 (quarter), C4 (quarter), A3 (quarter), C4 (quarter), B3 (quarter), A3 (quarter), B3 (quarter), A3 (quarter), B3 (quarter), A3 (quarter), B3 (quarter). The second staff contains notes for the lyrics: C4 (quarter), A3 (quarter), C4 (quarter), A3 (quarter), C4 (quarter), A3 (quarter), C4 (quarter), B3 (quarter), B3 (quarter), C4 (quarter), C4 (quarter), A3 (quarter), and a whole rest.

First fin - ger for A to C, se - cond fin - ger A to B,
when we prac - tise ev - ery day, we will sound O K.



Shave and a Haircut 36



Shave and a hair - cut, six - pence.



Four Note Song 37

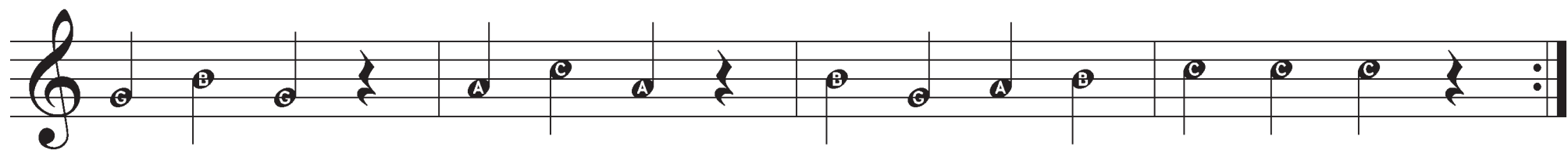

Lesson 10

The Note F

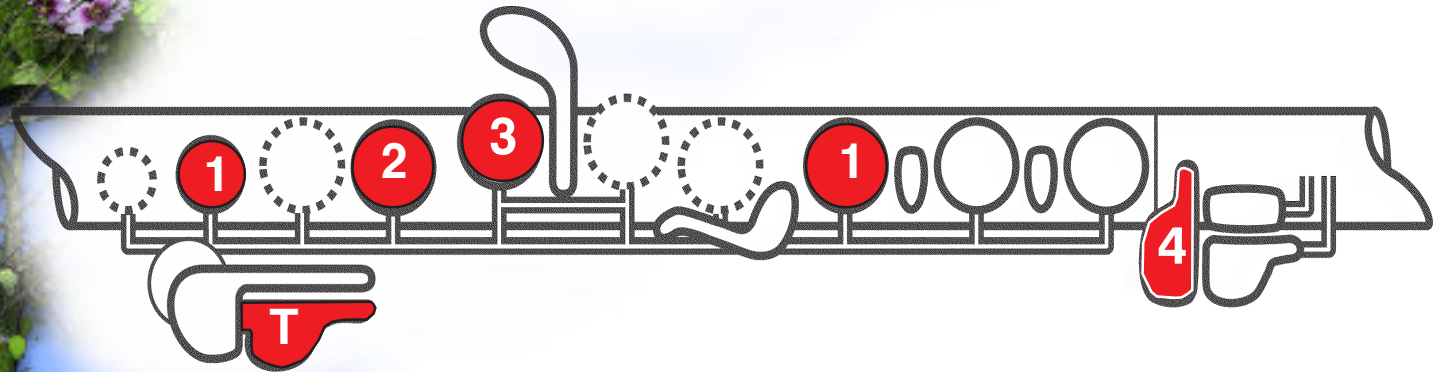

Fred the Frog



A musical staff in 4/4 time with a treble clef. It contains eight notes, all labeled 'F'. The notes are: quarter, quarter, quarter, quarter, quarter, quarter, quarter, quarter. Below the staff are the lyrics: "Fred the Frog lives in a bog." The numbers 1, 2, 3, and 4 are placed below the first four notes respectively.

A musical staff in 4/4 time with a treble clef. It contains eight notes, all labeled 'F'. The notes are: quarter, quarter, quarter, quarter, quarter, quarter, quarter, quarter. Below the staff are the lyrics: "Loves to croak at pas-sing folk. It's his joke!" The numbers 5, 6, 7, and 8 are placed below the first four notes respectively.

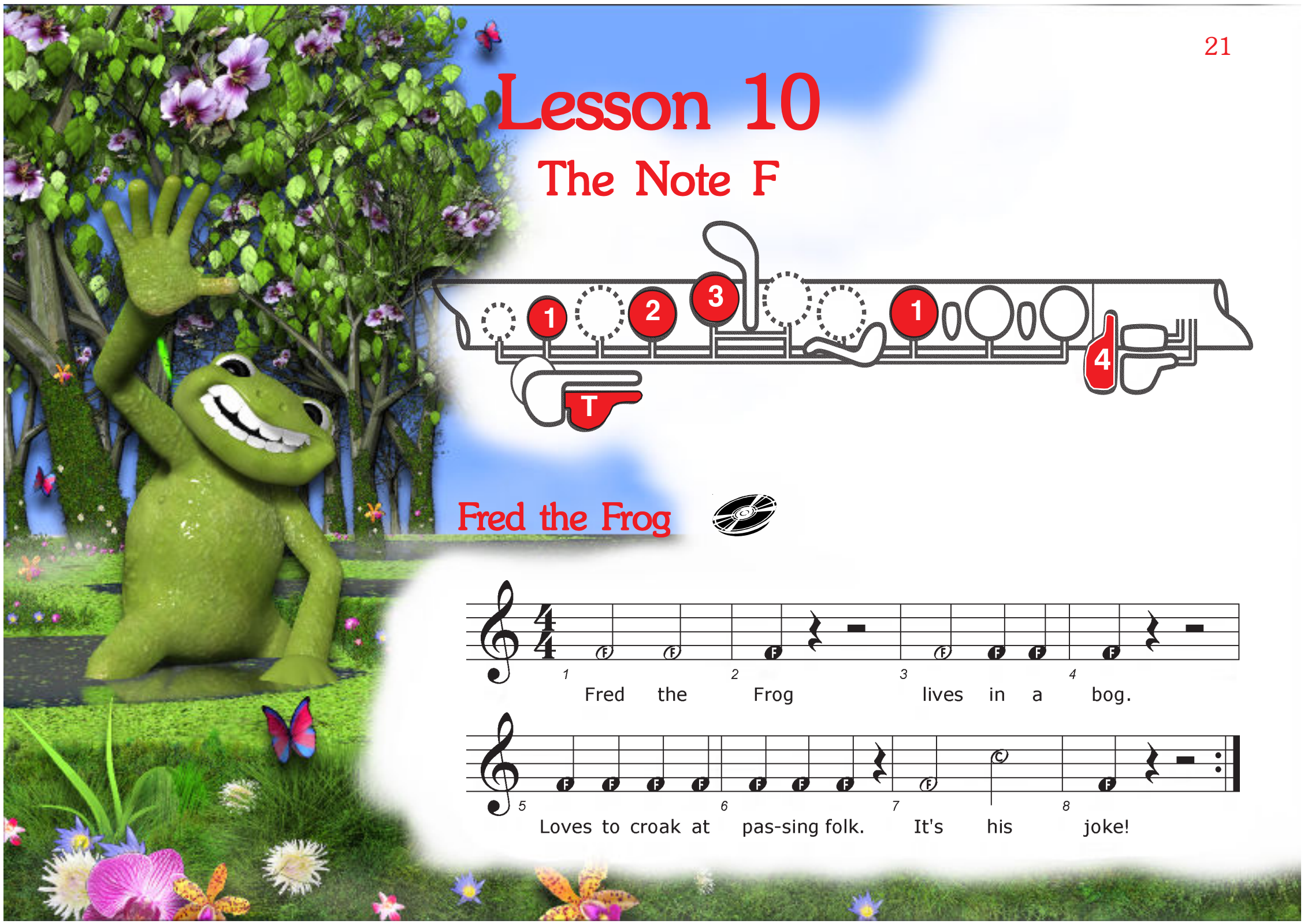

Fine Old Time



Let's all have a fine old time, just like yes-ter-day,
We will sing and dance a-round, eve-ry one can play.

Mary Had a Little Lamb



Ma-ry had a lit-tle lamb, - lit-tle lamb, lit-tle lamb.
Ma-ry had a - lit-tle lamb, it's fleece was white as snow.

Lesson 11

The Note B Flat (B \flat)

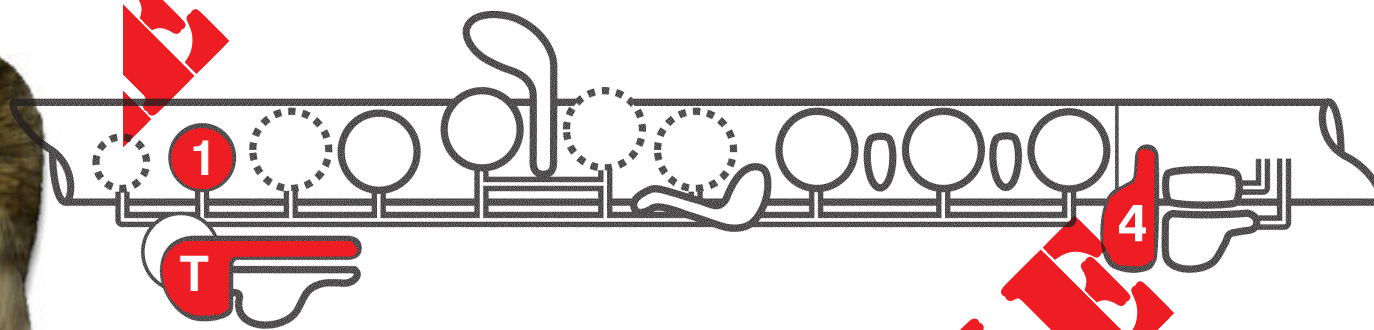
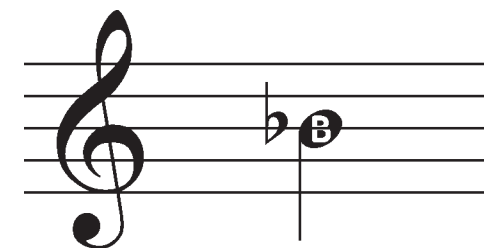

Brooke the Bear

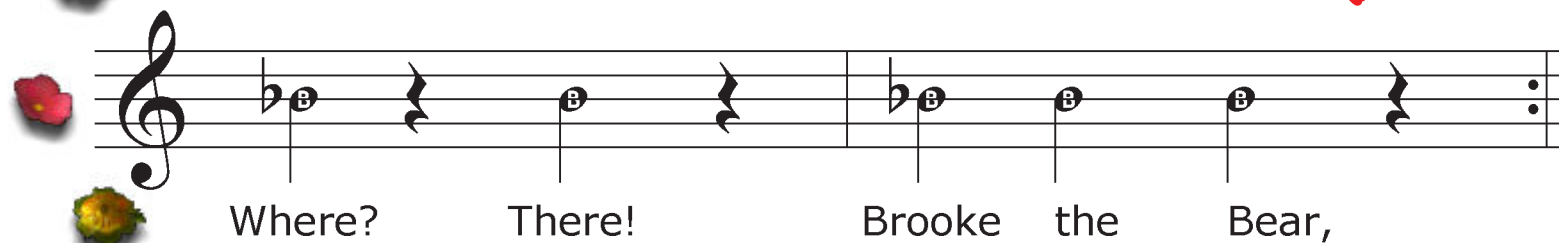

SAMPLE

The Dotted Half Note (or Dotted Minim)

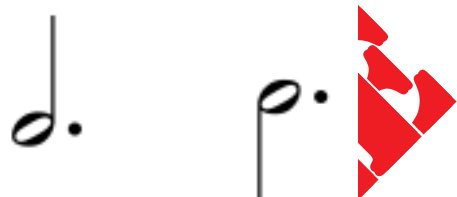

Adding a dot after a half note makes it last for 3 beats.

Brooke Meets Fred



Brooke the Bear said

"Let's all go see Fred!"

Detailed description: This block contains two staves of musical notation in 4/4 time. The first staff shows the melody for the lyrics 'Brooke the Bear said'. The notes are B-flat, B, B, and a dotted B-flat. The second staff shows the accompaniment for the lyrics '"Let's all go see Fred!"'. The notes are A, A, G, G, and a dotted F.

Brooke the Bear, and her Hair



All the B notes in this piece are B Flat

B Flat

Brooke the Bear has short hair, and she's so free of care, she's got time to spare.

Detailed description: This block contains two staves of musical notation in 4/4 time. The first staff covers the lyrics 'Brooke the Bear has short hair, and she's so'. The second staff covers 'free of care, she's got time to spare.'. Annotations include 'All the B notes in this piece are B Flat' with arrows pointing to B notes in both staves, and 'B Flat' with an arrow pointing to a B note in the second staff. The notes in the first staff are B-flat, B, B, B-flat, A, A, A, F, G, A. The notes in the second staff are B-flat, B, B-flat, A, F, G, A, B-flat.

Aura Lee



Keep your thumb on the B \flat key for every note except C.

1 As the black - bird 2 in the spring

3 'neath the wil - low 4 tree 5 sat and piped I

6 heard him sing, 7 sing of Au - ra 8 Lee.



Lightly Row



1 Light - ly row, 2 light - ly row, a 3 cross the rol - ing 4 waves we go.

5 Light - ly row, 6 light - ly row, a - 7 way from shore we 8 glide.

Five Fine Friends



The flat signs here means that all B notes in the song are B Flat

Co - co's here, Brooke is too, notes be - neath our fin - gers. Friends so long,
 when they're gone, how the sweet - ness lin - gers.

Detailed description: This block contains the musical score for the song 'Five Fine Friends'. It consists of two staves of music in 4/4 time. The first staff starts with a treble clef, a key signature of one flat (B-flat), and a 4/4 time signature. The melody begins with a quarter rest, followed by quarter notes C, C, C, and a quarter rest. The second measure contains quarter notes B-flat, B-flat, and B-flat. The third measure has quarter notes F, G, and A. The fourth measure has quarter notes B, G, and C. The fifth measure has a quarter rest, followed by quarter notes C, C, and C. The second staff continues the melody from measure 6. It starts with a quarter note B-flat, followed by quarter notes B-flat, B-flat, and a quarter rest. The seventh measure has quarter notes A, F, and C. The eighth measure has quarter notes B, A, and F. The piece ends with a double bar line and repeat dots.

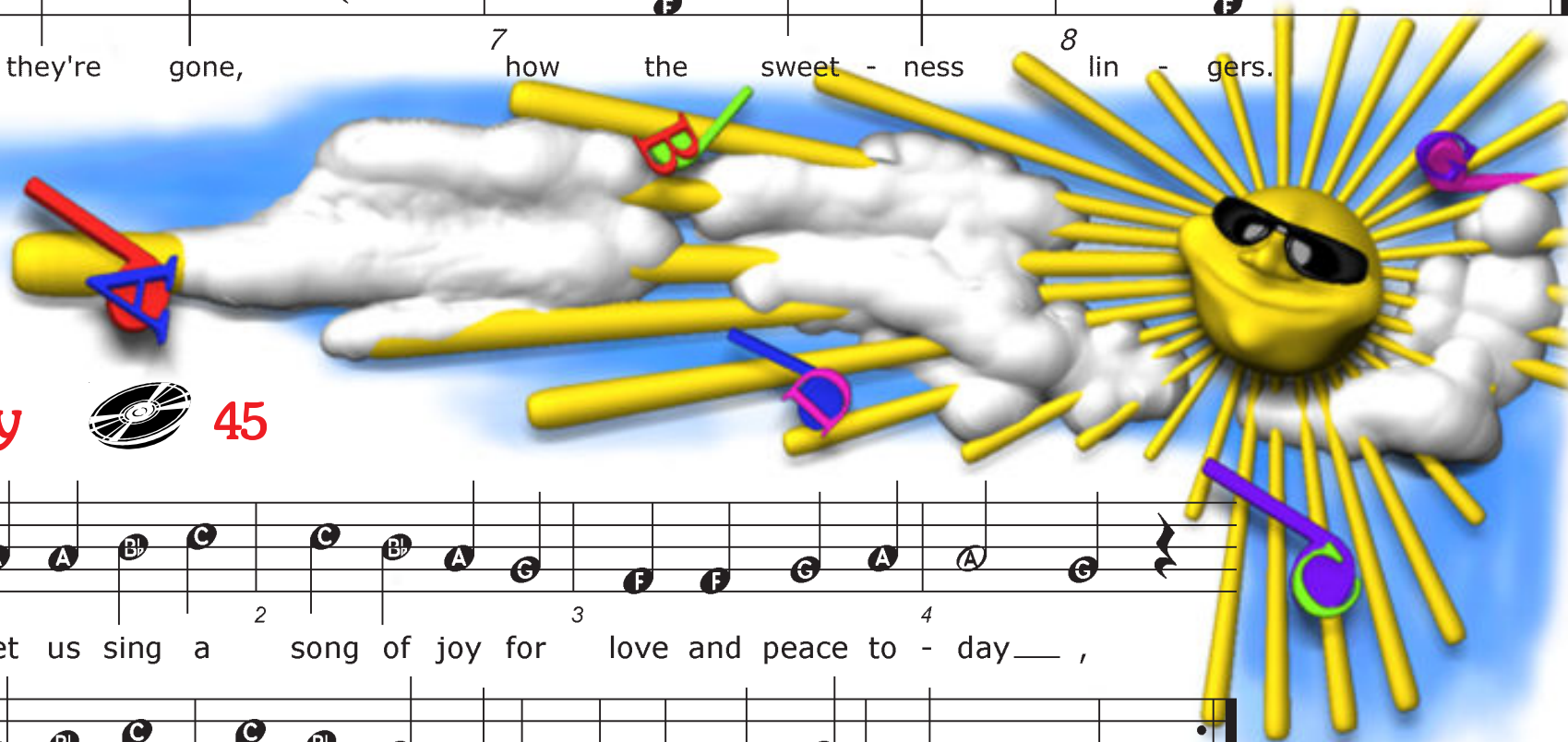

Ode to Joy



Let us sing a song of joy for love and peace to - day____ ,
 let us join our voi - ces now for God to whom we pray_____ .

Detailed description: This block contains the musical score for the first part of 'Ode to Joy'. It consists of two staves of music in 4/4 time. The first staff starts with a treble clef, a key signature of one flat (B-flat), and a 4/4 time signature. The melody begins with a quarter rest, followed by quarter notes A, A, B-flat, and C. The second measure contains quarter notes C, B-flat, and A. The third measure has quarter notes G, F, and F. The fourth measure has quarter notes G, A, and A. The second staff continues the melody from measure 5. It starts with a quarter note A, followed by quarter notes A, B-flat, and C. The sixth measure contains quarter notes C, B-flat, and A. The seventh measure has quarter notes G, F, and F. The eighth measure has quarter notes G, A, and G. The piece ends with a quarter note F and a double bar line with repeat dots.

Lesson 12

The Dotted Quarter Note (or Dotted Crotchet)



Adding a dot after a quarter note gives it a value of $\frac{3}{4}$ for 3 beats.

SAMPLE

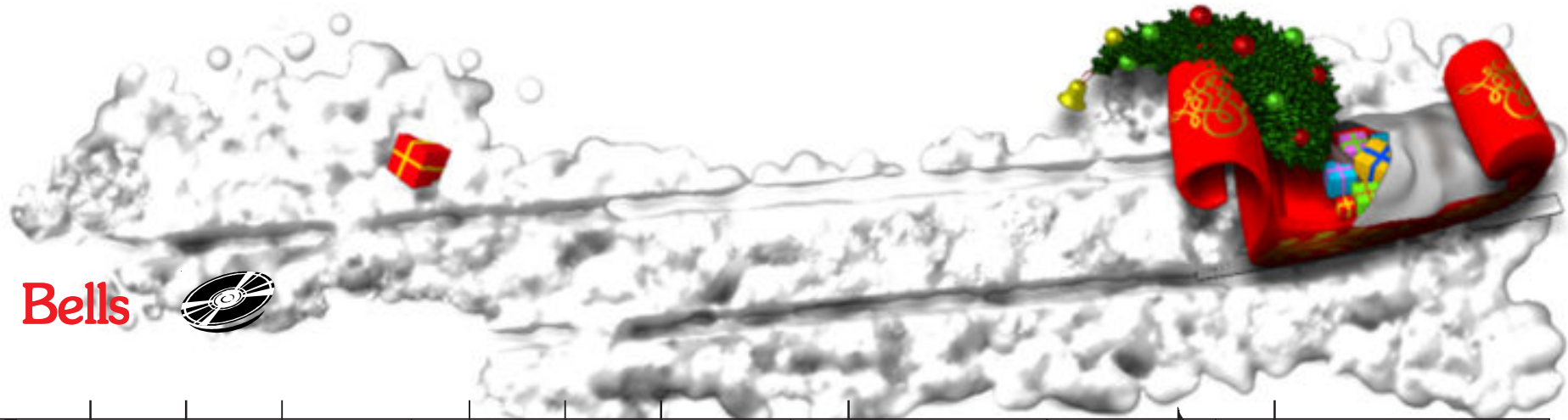

Jingle Bells



When the Saints Go Marchin' In 51

5 beats lead-in
on the CD



O when the saints go march - in' in,
 O when the saints go march - in' in,
 O Lord I want to be in that num - ber,
 when the saints go march - in in.



3
4

Lesson 13

The Three Four Time Signature



This time signature tells us that each bar has only 3 beats.

Three for All  Track 5



The space between two lines is called a bar.

Songs in three four time have only 3 beats count-in.

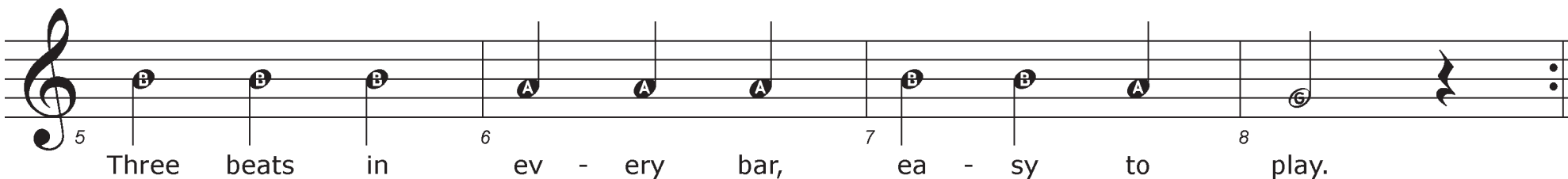
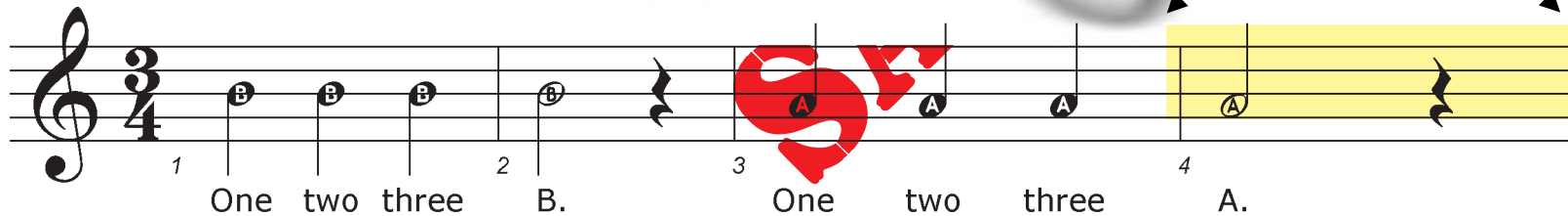

Oranges and Lemons



SAMPLE

SAMPLE



Lesson 14

George's Waltz



Track

George spins a - round, leaps off the ground,
Ann and Ben cheer with a migh - ty big sound.

Boys and Girls Come Out to Play



Track

Boys and girls come out to play! The
moon is shi - ning bright as day.



The Cuckoo



Track 9

5 beats lead-in on the CD

Musical notation for 'The Cuckoo' in 3/4 time. The melody consists of two staves. The first staff contains measures 1 through 4, and the second staff contains measures 5 through 8. The notes are: 1. C4, 2. A4, 3. C4, 4. A4, 5. G4, 6. F4, 7. G4, 8. A4. The lyrics are: 'Cuc - koo, cuc - koo, cuc - koo to you. Cuc - koo, cuc - koo, how do you do?'.

Four Note Waltz



Track 10

Musical notation for 'Four Note Waltz' in 3/4 time. The melody consists of two staves. The first staff contains measures 1 through 4, and the second staff contains measures 5 through 8. The notes are: 1. C4, 2. B4, 3. A4, 4. G4, 5. C4, 6. B4, 7. A4, 8. G4. The lyrics are: 'Give me that old - fash - ioned one two three dance. I love those won - der - ful steps of ro - mance.'.



SAMPLE

SAMPLE

Lesson 15

The Note D

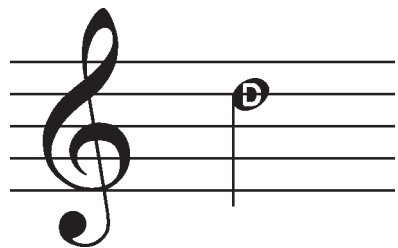

Run the Dog  38

SAMPLE

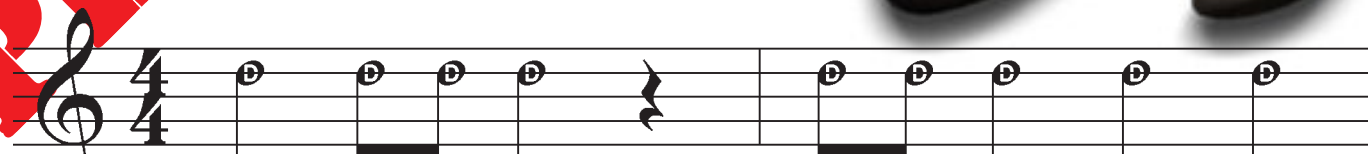

Dan is a dog. He's a big dog, he

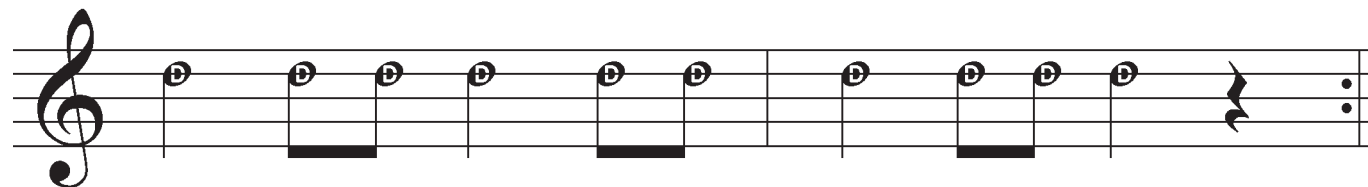

runs and he jumps and he sleeps like a log.



Run, Dan, Run  39



Run, Dan, run as you fetch the stick. Hur-ry, Dan, hur-ry you like to be quick.

40

Dan Likes a Pat 40

Dan likes a pat. Are you good at that?

 Dan likes to lick. Move your face a - way quick!

Dancing the Stairs 41

Danc - ing up the stairs,

 play - ing mu - si - cal chairs.

Half
(or Minim) Rest



Lesson 10



Finger Fun 42

1 2 3 4

5 6 7 8

Mary Had a Little Lamb 43



Ma - ry had a lit - tle lamb, - lit - tle lamb, lit - tle lamb.

Ma - ry had a - lit - tle lamb, it's fleece was white as snow.

42

Five Note Frolic



44

Musical notation for "Five Note Frolic" in 4/4 time. The melody consists of two staves. The first staff has notes D4, D4, D4, C4, C4, C4, G3, A3, B3, C4, A3, D4. The second staff has notes D4, D4, D4, C4, C4, C4, B3, G3, D4, C4, B3, G3. Lyrics are: "D for me, C for you, notes be - neath our fin - gers, Notes up high, near the sky, how the sweet - ness lin - gers!"

Ode to Joy



45

Musical notation for "Ode to Joy" in 4/4 time. The melody consists of two staves. The first staff has notes B3, B3, C4, D4, D4, C4, B3, A3, G3, G3, A3, B3, B3, A3. The second staff has notes B3, B3, C4, D4, D4, C4, B3, A3, G3, G3, A3, B3, A3, G3. Lyrics are: "1 Let us sing a 2 song of joy for 3 love and peace to - day___, 4 let us join our 6 voi - ces now for 7 God to whom we 8 pray_____."

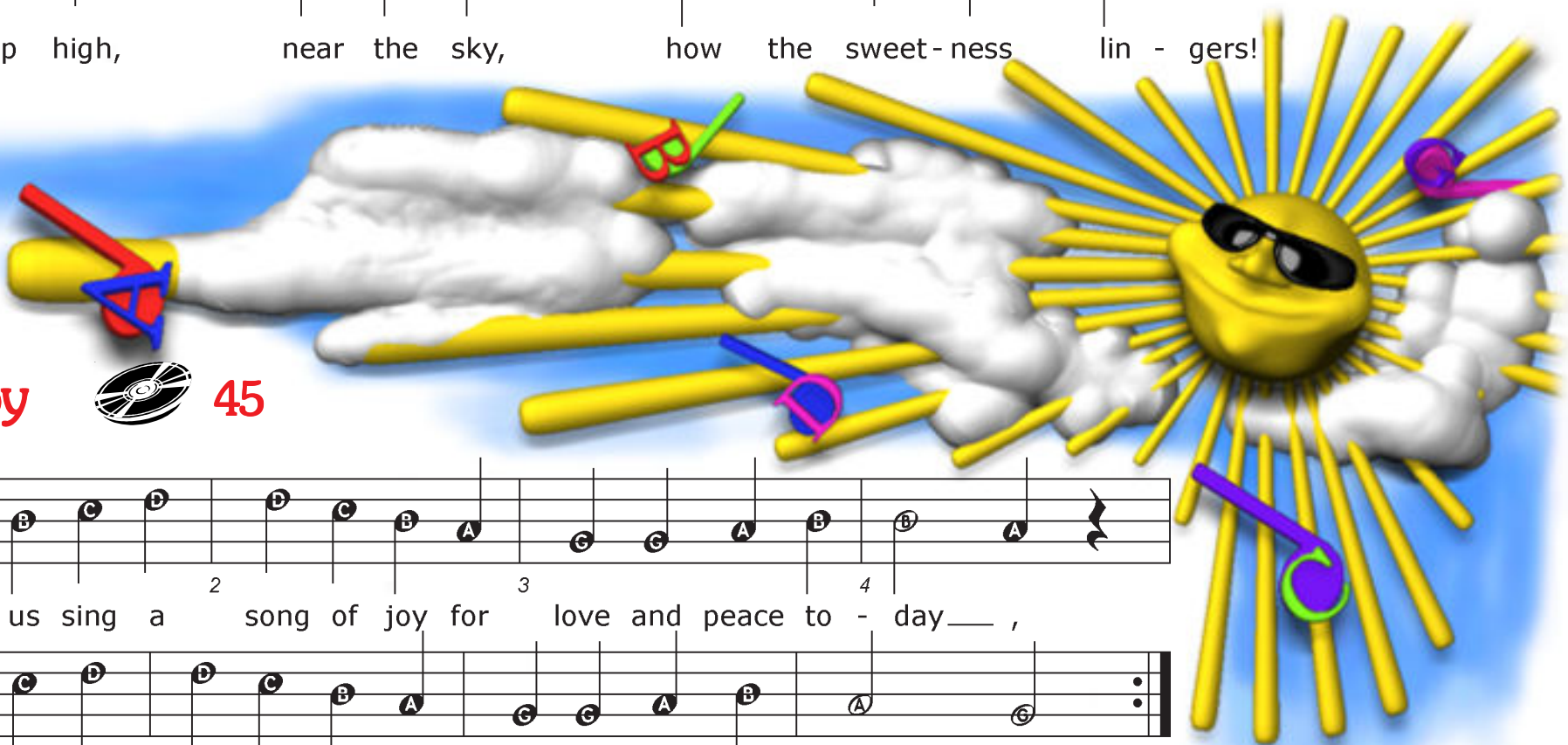

Lesson 11

Aura Lee 46

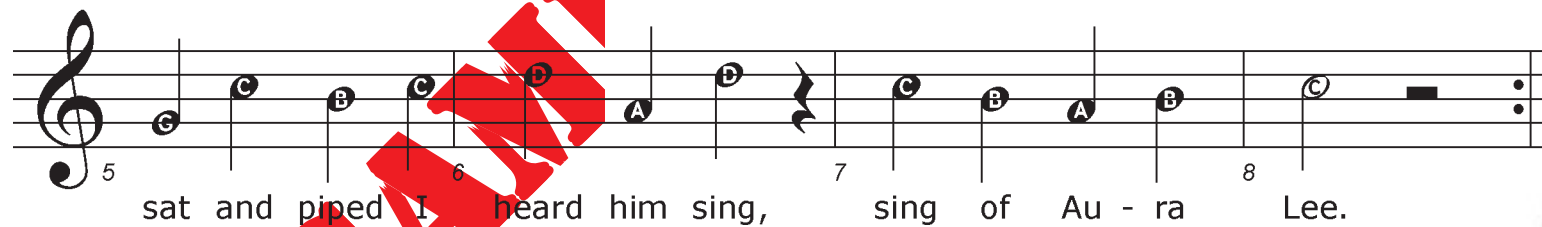
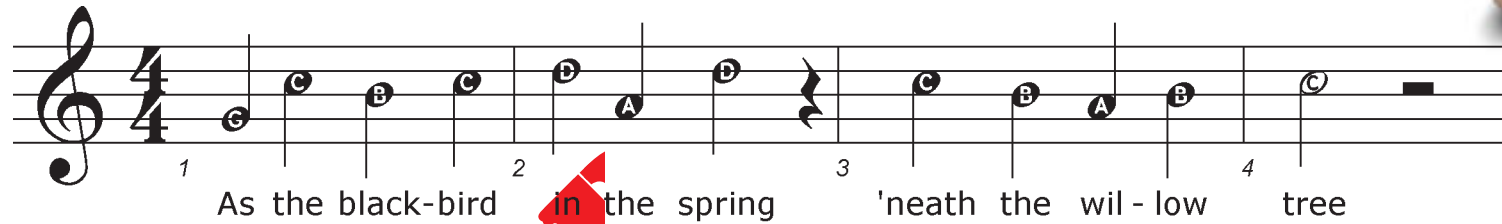

Lightly Row 47

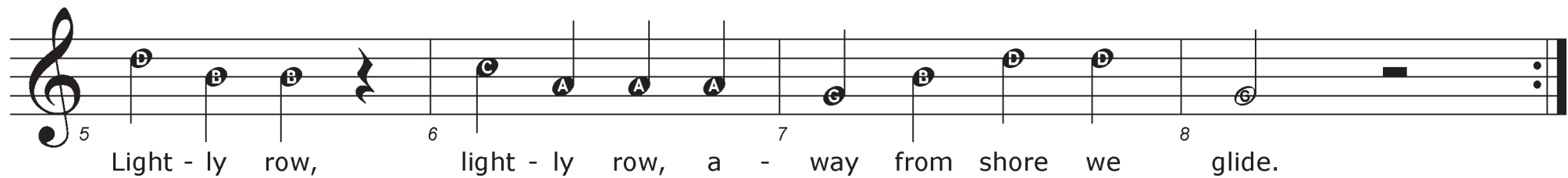
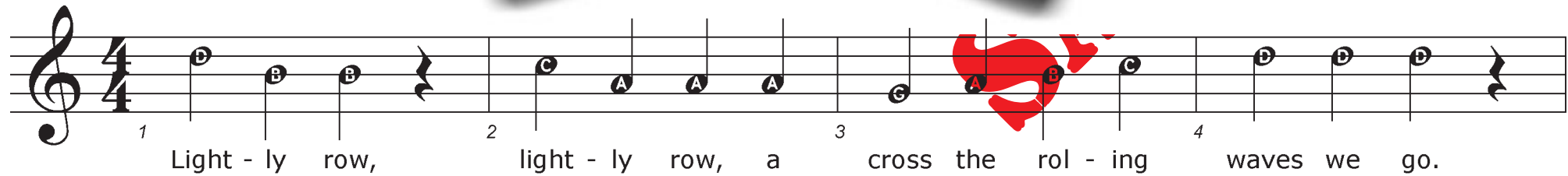

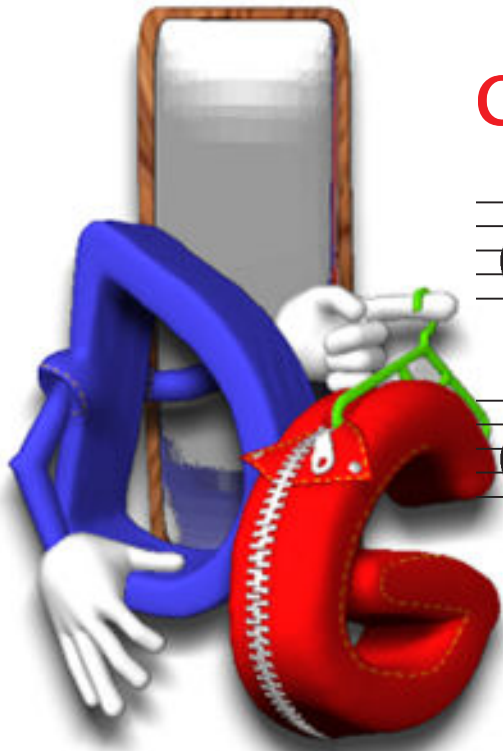

Changing from D to G 48

1 2 3 4
5 6 7 8



Spare Change 49

1 Here's some change I don't need now,
5 I'll get plenty more, and how!

Lesson 12

Jingle Bells



50

1 Jingle Bells, 2 Jingle Bells, 3 jingle all the way, 4

5 O what fun it 6 is to ride on a 7 one horse open 8 sleigh, hey!

9 Jingle Bells, 10 Jingle Bells, 11 jingle all the 12 way,

13 O what fun it 14 is to ride on a 15 one horse open 16 sleigh.

When the Saints Go Marchin' In 51

5 beats lead-in
on the CD



O when the saints go march-in' in, O when the
saints go march - in' in, O Lord I
want to be in that num - ber, when the
saints go march - in in.



Quiz

1. What is this called?



2. What is the name given to these 5 lines?

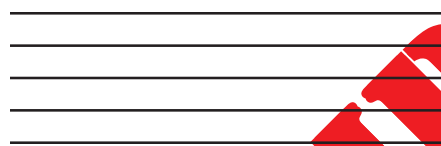

3. Name and play this note:



4. How many beats do we play for one of these notes?



5. What do these numbers mean?



6. What do these dots mean?

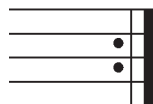

7. What is the name for this symbol?



8. How many beats does it get?

9. How do we play a C note?

10. What sort of note is this?



11. How many beats do we play it for?

